

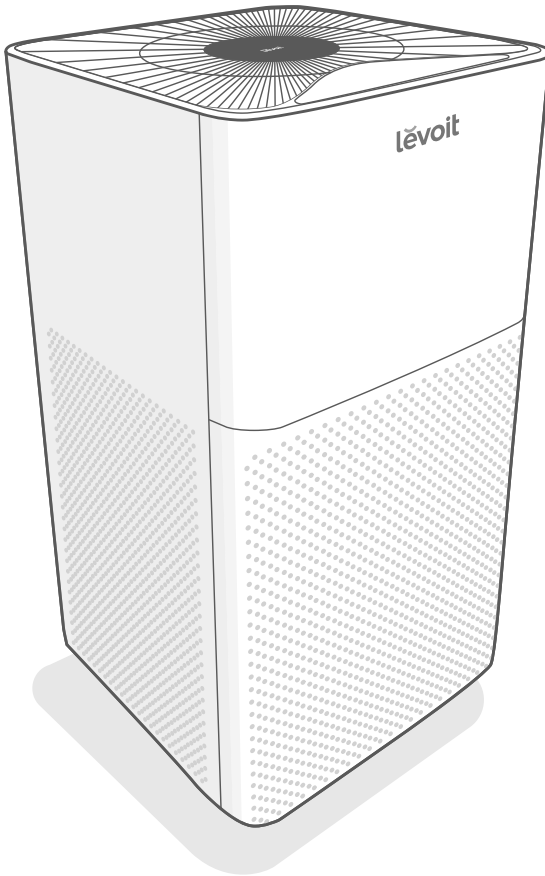

USER MANUAL

# Console Air Purifier

Model: LV-H135



## Questions or Concerns?

Please contact us Mon-Fri, 9:00 am–5:00 pm PST/PDT at [support@levoit.com](mailto:support@levoit.com) or at 1-888-726-8520.

## Table of Contents

|                                   |    |
|-----------------------------------|----|
| Package Contents                  | 2  |
| Specifications                    | 2  |
| Safety Information                | 3  |
| Getting to Know Your Air Purifier | 4  |
| LED Display                       | 5  |
| Getting Started                   | 6  |
| Using Your Air Purifier           | 8  |
| About the Filter                  | 10 |
| Care & Maintenance                | 12 |
| Troubleshooting                   | 15 |
| Warranty Information              | 17 |
| Customer Support                  | 19 |

## Package Contents

- 1 x Air Purifier
- 1 x 3-Stage Filter (Pre-Installed)
- 1 x User Manual

## Specifications

|                             |  |
|-----------------------------|--|
| <b>Power Supply</b>         | AC 120V, 60Hz  |
| <b>Rated Power</b>          | 40W  |
| <b>Operating Conditions</b> | <b>Temperature:</b> 14°–104°F / -10°–40°C<br><b>Humidity:</b> ≤ 85% RH |
| <b>Dimensions</b>           | 20.9 x 11.2 x 11.2 in / 53 x 28 x 28 cm                                |
| <b>Weight</b>               | 13.7 lb / 6.2 kg   |

# READ AND SAVE THESE INSTRUCTIONS

## SAFETY INFORMATION

To reduce the risk of fire, electric shock, or other injury, follow all instructions and safety guidelines.

### General Safety

- **Only** use your air purifier as described in this manual.
- **Do not** use without removing the plastic wrap from the filter. The air purifier will not filter air, and may overheat, causing a fire hazard.
- **Do not** use the air purifier outdoors.
- Keep the air purifier away from water, and wet or damp areas. **Never** place in water or other liquids.
- **Do not** use in excessively humid areas.
- Keep the air purifier away from heat sources.
- **Do not** use where combustible gases or vapors, metallic dust, aerosol (spray) products, or fumes from industrial oil are present.
- Keep 5 ft / 1.5 m away from where oxygen is being administered.
- Supervise children when they are near the air purifier.
- **Do not** place anything into any opening on the air purifier, unless directed by the manual.
- **Do not** sit or place heavy objects on the air purifier.
- Keep the inside of the air purifier dry. To prevent moisture buildup, avoid placing in rooms with major temperature changes.
- **Always** unplug the air purifier before servicing (for example, changing the filter).
- **Do not** use the air purifier if it is damaged or not working correctly, or if the cord or plug is damaged. **Do not** try to repair it yourself. **Contact Customer Support** (see page 19).
- **WARNING:** To reduce the risk of fire or electric shock, **do not** use this air purifier with any solid-state speed controls (such as a dimmer switch).

- Not for commercial use. Household use **only**.
- **WARNING:** To reduce the risk of fire, electric shock or injury to persons, **do not** use replacement parts that have not been recommended by the manufacturer.

### Power & Cord

- Keep the air purifier near the outlet it is plugged into.
- **Never** place the cord near any heat source.
- **Do not** cover the cord with a rug, carpet, or other covering. **Do not** place the cord under furniture or appliances.
- Keep the cord out of areas where people walk often. Place the cord where it will not be tripped over.
- This air purifier has a polarized plug (one blade is wider than the other). To reduce the risk of electric shock, this plug is intended to fit in a polarized outlet only one way. If the plug does not fit fully in the outlet, reverse the plug. If it still does not fit, contact a qualified electrician. **Do not** attempt to defeat this safety feature.

### Electromagnetic Fields (EMF)

Your Levoit air purifier complies with all standards regarding electromagnetic fields (EMF). If handled properly and according to the instructions in this user manual, the appliance is safe to use based on scientific evidence available today.

# GETTING TO KNOW YOUR AIR PURIFIER

- A. LED Display
- B. Air Outlet
- C. Housing
- D. Air Intake (Front and Back)
- E. Air Quality Sensor
- F. Sensor Cover Sponge
- G. Sensor Cover
- H. Safety Trigger
- I. Filter Cover
- J. Filter
- K. Power Cord

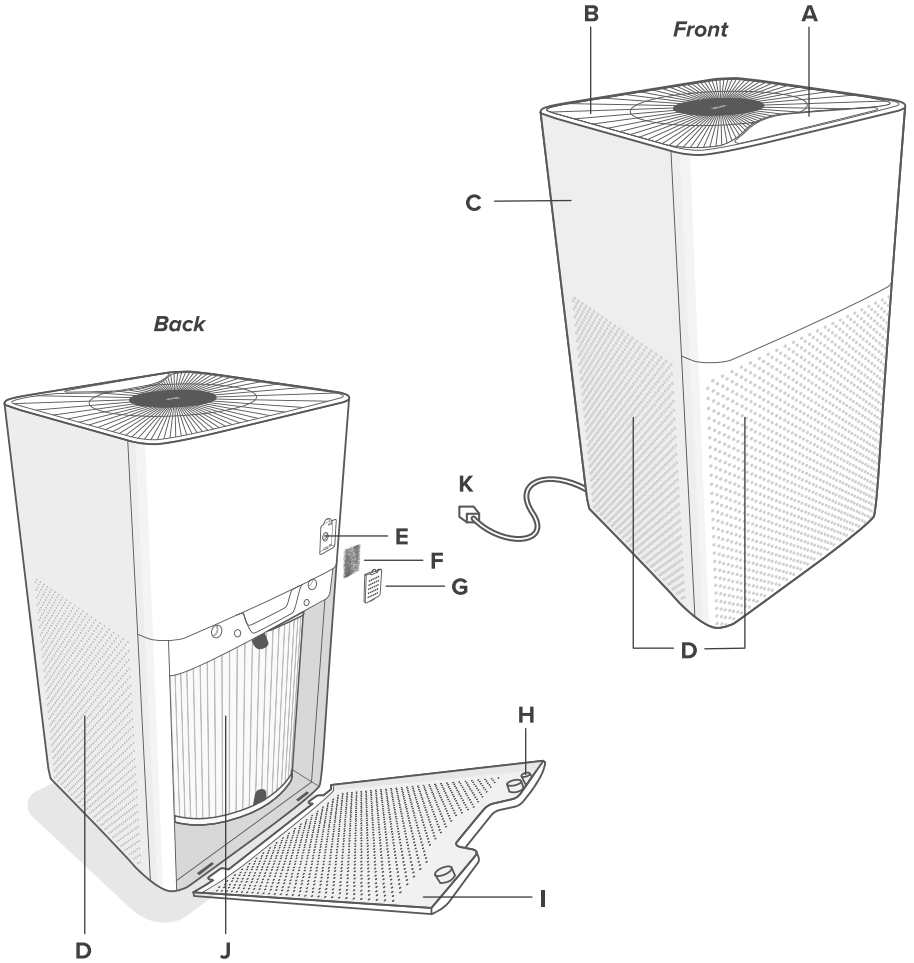



# LED DISPLAY

## Controls

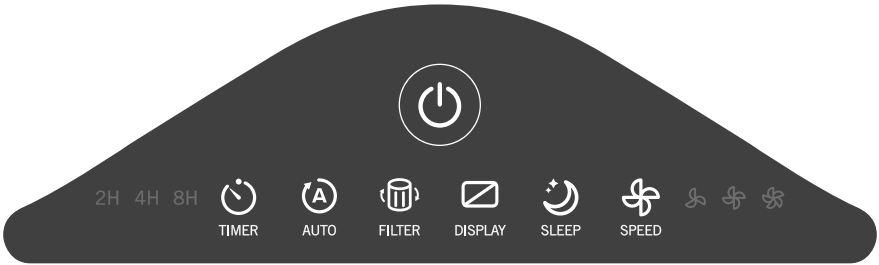

### On/Off Button

- Turns the air purifier on/off.



### Display Off Button

- Turns the display off.
- Press any button (except ) to turn the display back on.



### Timer Button

- Sets the timer and cycles through timer lengths (see page 8).



### Fan Speed Button

- Cycles through fan speeds: low, medium, and high.

*Fan Speed Chart*



### Auto Mode Button

- Turns Auto Mode on/off (see page 8).



### Check Filter Indicator

- Lights up when the filter should be checked (see **Check Filter Indicator**, page 12).

| Fan Speed | Fan Speed Indicator |
|-----------|---------------------|
| Low       |                     |
| Medium    |                     |
| High      |                     |



### Sleep Mode Button

- Turns Sleep Mode on/off (see page 8).

# GETTING STARTED

1. Pull the handle of the filter cover to open the housing. Remove the filter from the housing. [Figure 1.1]

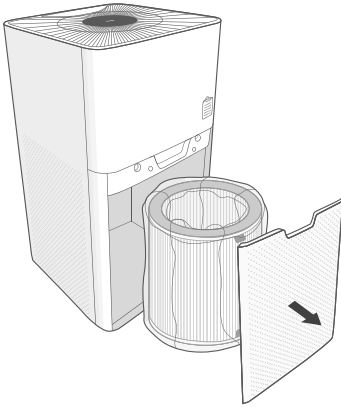

Figure 1.1

2. Remove the filter from its plastic packaging, then reinstall it into the housing. Make sure the pull tabs on the filter are facing out. [Figure 1.2]

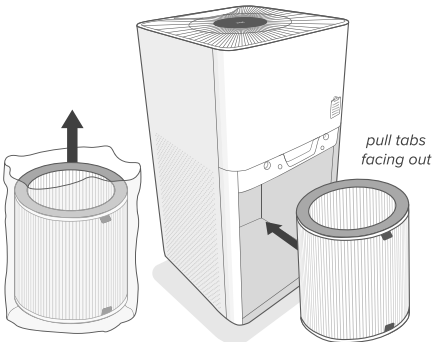

Figure 1.2

3. Replace the filter cover by lining up the cover's feet with the slots on the bottom of the housing. [Figure 1.3]

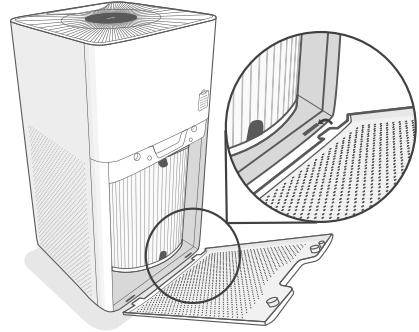
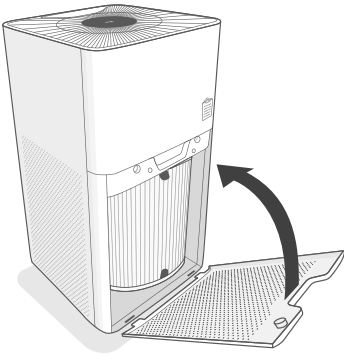

Figure 1.3

## GETTING STARTED (CONT.)

4. Push the cover securely closed.  
*[Figure 1.4]* The air purifier uses a magnetic safety trigger to make sure that the filter cover is closed. If not properly closed, the air purifier **will not** turn on.



*Figure 1.4*

5. Place the air purifier on a hard, flat surface. Leave 15 in / 38 cm of clearance on all sides of the air purifier.  
*[Figure 1.5]*

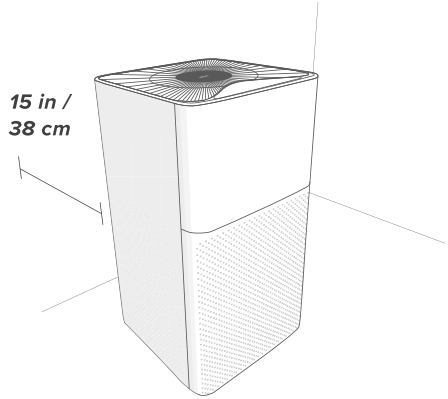



*Figure 1.5*

**Note:** If you are not planning to use the air purifier for a long period of time, we recommend keeping the filter clean by leaving it inside its plastic packaging until it is ready to be used.

# USING YOUR AIR PURIFIER

## General Operation



1. Plug in and press  to turn the air purifier on/off. The fan will start automatically.
2. Optionally, press  to change the fan speed. You can also select Auto Mode or Sleep Mode, or select a timer.

### Note:

- For best results, or to address a specific air quality issue such as smoke, run the air purifier at high speed for 15–20 minutes before using a lower speed or Auto Mode.
- To effectively clean air, keep windows and doors closed while the air purifier is operating.

## Auto Mode

Auto Mode uses the dust sensor inside the air purifier to adjust the fan speed automatically based on air quality. For example, if the air quality is bad, the fan will automatically be set to high speed.



- Press  to turn Auto Mode on/off.
- Pressing  or  will also exit Auto Mode.

## Automatic Shutoff

As a safety feature, the air purifier will automatically turn off if the filter cover is removed.

## Sleep Mode

Sleep Mode uses the lowest possible fan speed to create a quiet environment.

- Press  to turn Sleep Mode on/off.
- Pressing  or  will also exit Sleep Mode.

## Timer

- You can set a timer for 2, 4, or 8 hours.
- Press  to cycle through timer options and turn the timer off. The timer will start automatically.
- Once the timer has finished, the air purifier will turn off.

### Note:

- You can change the fan speed at any time while the timer is on. The timer will work with any mode.
- The timer will restart if the time is changed.
- Pressing  or unplugging the air purifier will cancel the timer.

## Memory Function

The air purifier will remember its programmed settings when turned off, and will resume these settings when turned back on.

**Note:** The air purifier will not remember timers.

## USING YOUR AIR PURIFIER (CONT.)

### Air Quality Indicator

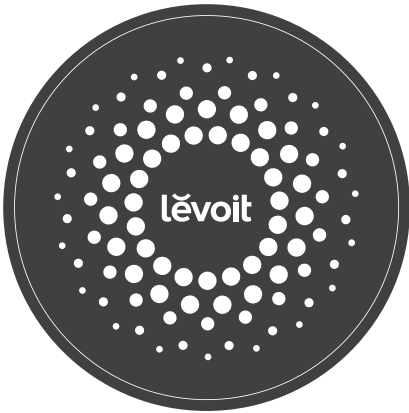

This indicator uses an automatic sensor to display the air quality.

*Air Quality Indicator Chart*

| Indicator Color | Air Quality | Fan Speed  |
|-----------------|-------------|------------|
| Blue            | Very Good   | Sleep Mode |
| Green           | Good        | Low        |
| Yellow          | Moderate    | Medium     |
| Red             | Bad         | High       |

### Changing Brightness

Use the palm of your hand to press the air quality indicator to change the brightness.

**Note:** Touching with just a fingertip may not change the brightness.

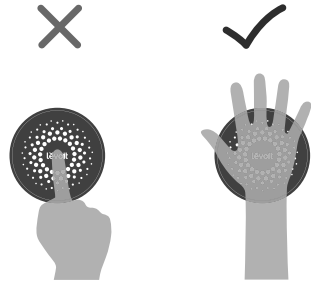

## USING YOUR AIR PURIFIER (CONT.)

### About the Filter

This air purifier uses a 3-stage filtration system to purify air.

#### A. Pre-Filter

- Captures large particles such as dust, lint, fibers, hair, and pet fur.

#### B. Main Filter

- Traps small particles such as fine dust, smoke particles.

#### C. Activated Carbon Filter

- Physically adsorbs smoke, odors, and fumes.

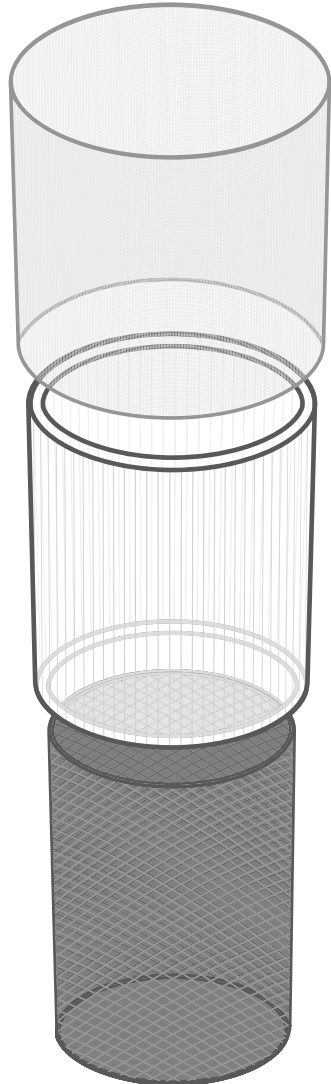

## USING YOUR AIR PURIFIER (CONT.)

### Humidity

Moisture may damage the filter. This air purifier should be used in an area with a humidity level below 85% RH. If you use the air purifier in excessively humid areas, the surface of the filter will become moldy.

**Note:** *Water or moisture will allow mold to grow. To solve a mold problem, get rid of the source of the moisture and clean up the mold.*

### Essential Oils

**Do not** add essential oils to the air purifier or filter. The filters will become damaged by the oil and will eventually release an unpleasant smell. **Do not** use oil diffusers near the air purifier.

# CARE & MAINTENANCE

## Cleaning the Air Purifier

**Note:** Do not clean with abrasive chemicals or flammable cleaning agents.

1. Unplug before cleaning.
2. Wipe the outside of the air purifier with a soft, dry cloth. If necessary, wipe the housing with a damp cloth, then immediately dry.
3. Vacuum the inside of the air purifier.

## Cleaning the Sensor Cover

If the air quality indicator does not seem to be accurate, clean the sensor cover.

1. Remove the sensor cover. [Figure 2.1]

**Note:** The sensor cover has a sponge inside to protect the air quality sensor from large particles.

2. Wipe the cover with a dry cloth. Wash the sponge with clean water, then dry.
3. Replace the sponge into the sensor cover, and then replace the sensor cover.

**Note:** Do not throw away the sponge. If the sponge is not in the sensor cover, the air quality sensor may not work correctly.

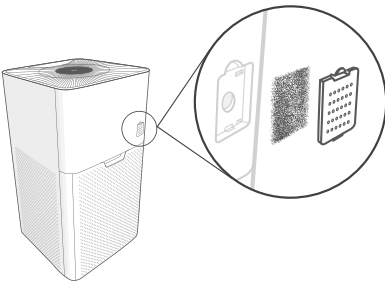









Figure 2.1

## Check Filter Indicator

 will light up as a reminder to check the filter. Depending on how often you use the air purifier, the indicator should turn on within 6–8 months. You may not need to replace your filter yet, but you should check it when  turns on.

## Resetting the Check Filter Indicator

Reset the Check Filter Indicator when:

-  lights up.
  1. Replace the filter (see page 14).
  2. Turn on the air purifier.
  3. Press and hold  for 3 seconds.
  4. The light will turn off after the filter indicator is successfully reset.
- The filter was changed before  lit up.
  1. Press and hold  for 3 seconds until  lights up.
  2. Press and hold  again for 3 seconds.
  3. The light will turn off after the filter indicator is successfully reset.



## CARE & MAINTENANCE (CONT.)

### When Should I Replace the Filter?

The filter should be replaced every 6–8 months. You may need to replace your filter earlier or later depending on how often you use your air purifier. Using your air purifier in an environment with relatively high pollution may mean you will need to change the filter more often, even if  is off.

You may need to replace your filter if you notice:

- Increased noise when the air purifier is on
- Decreased airflow
- Unusual odors
- A visibly clogged filter

#### Note:

- To maintain the performance of your air purifier, **only** use official Levoit filters. To buy replacement filters, visit Levoit's online store. Go to [levoit.com](https://levoit.com) for more information.
- Remember to reset  after changing the filter.

### Replacing the Filter

1. Unplug the air purifier and remove the filter cover. *[Figure 2.2]*

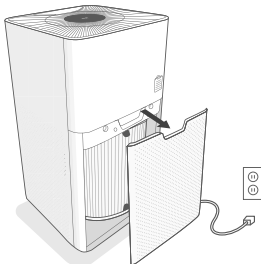

Figure 2.2

2. Remove the old filter. *[Figure 2.3]*

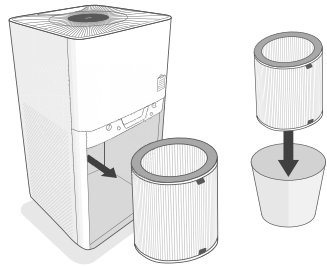

Figure 2.3

3. Clean out any remaining dust or hair inside the air purifier using a vacuum hose. **Do not** use water or liquids to clean the air purifier. *[Figure 2.4]*

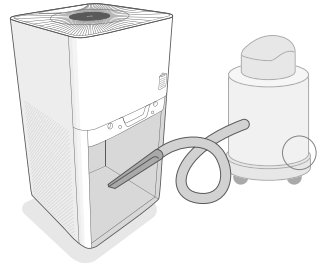

Figure 2.4

4. Unwrap the new filter and place it into the housing. Make sure the pull tabs are facing out. *[Figure 2.5]*

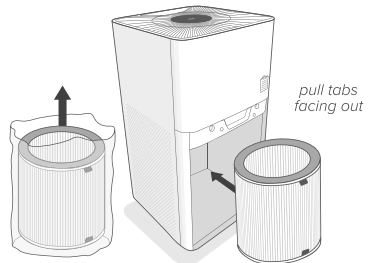

Figure 2.5

## Replacing the Filter (cont.)

5. Replace the filter cover. The air purifier will not power on unless the cover is replaced correctly. [Figure 2.6]

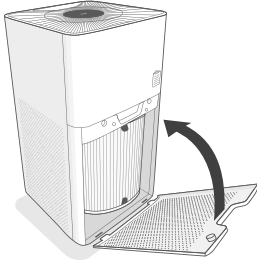



Figure 2.6

6. Plug in and turn on the air purifier.
7. Reset the Check Filter Indicator (see page 12).









## Storage

If not using the air purifier for an extended period of time, wrap the filter in plastic packaging and store in a dry place to avoid moisture damage.

# TROUBLESHOOTING

| Problem  | Possible Solution   |
|--|---|
| <p><b>Air purifier will not turn on or respond to button controls.</b></p> | <p>Plug in the air purifier.</p>  |
|  | <p>Check to see if the power cord is damaged. If it is, stop using the air purifier and contact <b>Customer Support</b> (see page 19).</p>  |
|  | <p>Securely close the filter cover so that the safety switch is activated (see page 7).</p>   |
|  | <p>Plug the air purifier into a different outlet.</p>   |
|  | <p>Air purifier is malfunctioning. Contact <b>Customer Support</b> (see page 19).</p>   |
| <p><b>Air purifier makes an unusual noise while the fan is on.</b></p>     | <p>Make sure the filter is removed from its packaging and properly in place (see page 6).</p>   |
|  | <p>Replace the filter (see page 14).</p>  |
|  | <p>Air purifier may be damaged, or a foreign object may be inside. Stop using the air purifier and contact <b>Customer Support</b> (see page 19). <b>Do not</b> try to repair the air purifier.</p> |
| <p><b>Airflow is significantly reduced.</b></p>                            | <p>Make sure the filter is properly in place with plastic packaging removed (see page 6).</p>   |
|  | <p>Press  to increase the fan speed.</p>   |
|  | <p>Make sure there is clearance of at least 15 in / 38 cm on all sides of the air purifier.</p>   |
|  | <p>The pre-filter may be clogged by large particles, such as hair or lint, blocking airflow. Clean the pre-filter (see page 12).</p>  |
|  | <p>Replace the filter (see page 14).</p>  |

TROUBLESHOOTING (CONT.)

| Problem   | Possible Solution   |
|---|---|
| <p>Poor air purification quality.</p>   | <p>Press  to increase the fan speed.</p>   |
|   | <p>Make sure no objects are blocking the top or sides of the air purifier (the inlet or outlet).</p>  |
|   | <p>Close doors and windows while running the air purifier.</p>  |
|   | <p>Make sure the filter is removed from its packaging and properly in place (see page 6).</p>   |
|   | <p>Close doors and windows while running the air purifier.</p>  |
|   | <p>If the room is larger than 463 ft<sup>2</sup> / 43 m<sup>2</sup>, air purification will take longer. The air purifier may not be as effective in significantly larger rooms.</p>   |
|   | <p>Clean the sensor cover (see page 12).</p>  |
|   | <p>Replace the filter (see page 14).</p>  |
| <p>Strange smell coming from the air purifier.</p>  | <p>Clean the filter, or replace if necessary.</p>   |
|   | <p>Contact <b>Customer Support</b> (see page 19).</p>   |
|   | <p>Make sure not to use your air purifier in an area with high humidity (over 85% RH) or while diffusing essential oils.</p>  |
| <p> is still illuminated after replacing the filter.</p> | <p>Reset  (see page 12).</p>   |
| <p> has not turned on within 8 months.</p>              | <p> is a reminder for you to check the filter and will light up based on how much the air purifier has been used (see page 12). If you don't use your air purifier often,  will take longer to turn on.</p> |
| <p> turned on before 6 months.</p>                     | <p> is a reminder for you to check the filter and will light up based on how much the air purifier has been used (see page 12). If you run your air purifier frequently,  will turn on sooner.</p>        |

If your problem is not listed, please contact **Customer Support** (see page 19)

# FCC INTERFERENCE STATEMENT

This device complies with Part 15 of the FCC Rules. Operation is subject to the following two conditions:

(1) This device may not cause harmful interference, and (2) This device must accept any interference received, including interference that may cause undesired operation.

NOTE: This equipment has been tested and found to comply with the limits for a Class B digital device, pursuant to part 15 of the FCC Rules. These limits are designed to provide reasonable protection against harmful interference in a residential installation.

This equipment generates, uses and can radiate radio frequency energy and, if not installed and used in accordance with the instructions, may cause harmful interference to radio communications. However, there is no guarantee that interference will not occur in a particular installation. If this equipment does cause harmful interference to radio or television reception, which can be determined by turning the equipment off and on, the user is encouraged to try to correct the interference by one or more of the following measures:

- Reorient or relocate the receiving antenna.
- Increase the separation between the equipment and receiver.
- Connect the equipment into an outlet on a circuit different from that to which the receiver is connected.
- Consult the dealer or an experienced radio/TV technician for help.

**FCC Caution:** Any changes or modifications not expressly approved by the party responsible for compliance could void the user's authority to operate this equipment.

## FCC SDOC SUPPLIER'S DECLARATION OF CONFORMITY

Arovast Corporation hereby declares that this equipment is in compliance with the FCC requirements. The declaration of conformity may be consulted in the support section of our website, accessible from [www.levoit.com](http://www.levoit.com)

# WARRANTY INFORMATION

|  |                      |
|--|----------------------|
| Product Name   | Console Air Purifier |
| Model  | LV-H135              |
| <i>For your own reference, we strongly recommend that you record your order ID and date of purchase.</i> |                      |
| Date of Purchase   |                      |
| Order ID   |                      |

## Levoit Limited Product Warranty

Register your products at <https://warranty.levoit.com/warranty> to stay up to date with important product information such as product updates, limited warranties, usage and maintenance recommendations, and notifications concerning safety warnings or product recalls. Registration is not required to claim your limited warranty.

## Two (2) Year Limited Consumer Product Warranty

Arovast Corporation ("Arovast") warrants that the product shall be free from defects in material and workmanship for a period of **2 years from the date of original purchase** ("Limited Warranty Period"), provided the product was used in accordance with its use and care instructions (e.g., in the intended environment and under normal circumstances).

## Your Limited Warranty Benefits

During the Limited Warranty Period and subject to this limited Warranty Policy, Arovast will, in its sole and exclusive discretion, either (i) refund the purchase price if the purchase was made directly from the online Levoit store, (ii) repair any defects in material or workmanship, (iii) replace the product with another product of greater value, or (iv) provide store credit in the amount of the purchase price.

## Who is Covered?

This limited warranty extends only to the original consumer purchaser of the product and is not transferable to any subsequent owner of the product, regardless of whether the product transferred ownership during the specified term of the limited warranty. The original consumer purchaser must provide verification of the defect or malfunction and proof of the date of purchase to claim the Limited Warranty Benefits.

## Be Aware of Unauthorized Dealers or Sellers

This limited warranty does not extend to products purchased from unauthorized dealers or sellers. Arovast's limited warranty only extends to products purchased from authorized dealers or sellers that are subject to Arovast's

quality controls and have agreed to follow its quality controls. Please be aware, products purchased from an unauthorized website or dealer may be counterfeit, used, defective, or may not be designed for use in your country. You can protect yourself and your products by making sure you only purchase from Arovast or its authorized dealers. If you have any questions about a specific seller, or if you think you may have purchased your product from an unauthorized seller, please contact our Customer Support Team via support@levoit.com.

#### What's Not Covered?

- Normal wear and tear, including parts that might wear out over time (e.g., batteries, filters, cleaning brush, essential oil pads, etc.).
- If the proof-of-purchase has been altered in any way or is made illegible.
- If the model number, serial number or production date code on the product has been altered, removed or made illegible.
- If the product has been modified from its original condition.
- If the product has not been used in accordance with directions and instructions in the user manual.
- Damages caused by connecting peripherals, additional equipment or accessories other than those recommended in the user manual.
- Damages or defects caused by accident, abuse, misuse, or improper or inadequate maintenance.
- Damages or defects caused by service or repair of the product performed by an unauthorized service provider or by anyone other than Arovast.
- Damages or defects occurring during commercial use, rental use, or any use for which the product is not intended.
- If the unit has been damaged, including but not limited to damage by animals, lightning, abnormal voltage, fire, natural disaster, transportation, dishwasher, or water (unless the user manual expressly states that the product is dishwasher-safe).
- Incidental and consequential damages.
- Damages or defects exceeding the cost of the product.

#### Claiming Your Limited Warranty Service in 5 Simple Steps:

1. Make sure your product is within the specified limited warranty period.
2. Make sure you have a copy of the invoice and order ID or proof-of-purchase.
3. Make sure you have your product. **DO NOT** dispose of your product before contacting us.
4. Contact our Customer Support Team via support@levoit.com
5. Once our Customer Support Team has approved your request, please return the product with a copy of the invoice and order ID.

#### Sole and Exclusive Remedy

THE FOREGOING LIMITED WARRANTY CONSTITUTES AROVAST CORPORATION'S EXCLUSIVE LIABILITY, AND YOUR SOLE AND EXCLUSIVE REMEDY, FOR ANY BREACH OF ANY WARRANTY OR OTHER NONCONFORMITY OF THE PRODUCT COVERED BY THIS LIMITED PRODUCT WARRANTY STATEMENT. THIS LIMITED WARRANTY IS EXCLUSIVE, AND IN LIEU OF ALL OTHER WARRANTIES. NO EMPLOYEE OF AROVAST CORPORATION OR ANY OTHER PARTY IS AUTHORIZED TO MAKE ANY WARRANTY IN ADDITION TO THE LIMITED WARRANTY IN THIS LIMITED PRODUCT WARRANTY STATEMENT.

#### Disclaimer of Limited Warranties

TO THE FULLEST EXTENT PROVIDED BY APPLICABLE LAW, EXCEPT AS WARRANTED IN THIS LIMITED PRODUCT WARRANTY POLICY, AROVAST CORPORATION PROVIDES THE PRODUCTS YOU PURCHASE FROM AROVAST CORPORATION "AS IS" AND AROVAST CORPORATION HEREBY DISCLAIMS ALL WARRANTIES OF ANY KIND, WHETHER EXPRESS OR IMPLIED, STATUTORY, OR OTHERWISE, INCLUDING BUT NOT LIMITED TO ANY WARRANTIES OF MERCHANTABILITY, NON-INFRINGEMENT, AND FITNESS FOR PARTICULAR PURPOSE.

#### Limitations of Liability

TO THE FULLEST EXTENT PROVIDED BY APPLICABLE LAW, IN NO EVENT WILL AROVAST CORPORATION, ITS AFFILIATES, OR THEIR LICENSORS, SERVICE PROVIDERS, EMPLOYEES, AGENTS, OFFICERS, OR DIRECTORS BE LIABLE FOR:

(a) DAMAGES OF ANY KIND ARISING OUT OF OR IN CONNECTION WITH PRODUCTS PURCHASED FROM AROVAST CORPORATION IN EXCESS OF THE PURCHASE PRICE PAID BY THE PURCHASER FOR SUCH PRODUCTS, OR

(b) INDIRECT, SPECIAL, INCIDENTAL, CONSEQUENTIAL, OR PUNITIVE DAMAGES EVEN IF AROVAST CORPORATION OR ONE OF ITS SUPPLIERS HAS BEEN ADVISED OF THE POSSIBILITY OR LIKELIHOOD OF SUCH DAMAGES.

AND REGARDLESS OF WHETHER CAUSED BY TORT (INCLUDING NEGLIGENCE), BREACH OF CONTRACT, OR OTHERWISE. OUR LIABILITY SHALL UNDER NO CIRCUMSTANCES EXCEED THE ACTUAL AMOUNT PAID BY YOU FOR THE DEFECTIVE PRODUCT, NOR SHALL WE UNDER ANY CIRCUMSTANCES BE LIABLE FOR ANY CONSEQUENTIAL, INCIDENTAL, SPECIAL OR PUNITIVE DAMAGES OR LOSSES, WHETHER DIRECT OR INDIRECT.

EXCEPT AS COVERED BY THIS LIMITED PRODUCT WARRANTY STATEMENT, AROVAST CORPORATION SHALL NOT BE LIABLE FOR COSTS ASSOCIATED WITH THE REPLACEMENT OR REPAIR OF PRODUCTS PURCHASED FROM IT, INCLUDING, BUT NOT LIMITED TO, LABOR, INSTALLATION, OR OTHER COSTS INCURRED BY THE USER AND, IN PARTICULAR, ANY COSTS RELATING TO THE REMOVAL OR REPLACEMENT OF ANY PRODUCT.

## OTHER RIGHTS YOU MAY HAVE

SOME JURISDICTIONS DO NOT ALLOW FOR: (1) EXCLUSION OF IMPLIED WARRANTIES; (2) LIMITATION ON THE DURATION OF IMPLIED WARRANTIES; AND/ OR (3) EXCLUSION OR LIMITATION OF INCIDENTAL OR CONSEQUENTIAL DAMAGES; SO THE DISCLAIMERS IN THIS POLICY MAY NOT APPLY TO YOU. IN THESE JURISDICTIONS YOU HAVE ONLY THE IMPLIED WARRANTIES THAT ARE EXPRESSLY REQUIRED TO BE PROVIDED IN ACCORDANCE WITH APPLICABLE LAW. THE LIMITATIONS OF WARRANTIES, LIABILITY, AND REMEDIES APPLY TO THE MAXIMUM EXTENT PERMITTED BY LAW.

ALTHOUGH THIS LIMITED WARRANTY GIVES YOU SPECIFIC LEGAL RIGHTS, YOU MAY HAVE OTHER RIGHTS IN YOUR JURISDICTION. THIS STATEMENT OF LIMITED WARRANTY IS SUBJECT TO APPLICABLE LAWS THAT APPLY TO YOU AND THE PRODUCT. PLEASE REVIEW THE LAWS IN YOUR JURISDICTION TO UNDERSTAND YOUR RIGHTS FULLY.

## CHANGES TO THIS POLICY

We may change the terms and availability of this limited warranty at our discretion, but any changes will not be retroactive.

This warranty is made by:

### **AROVAST CORPORATION**

1202 N. Miller St., Suite A  
Anaheim, CA 92806, USA

# CUSTOMER SUPPORT

If you have any questions or concerns about your new product, please contact our helpful Customer Support Team.

**Email:** [support@levoit.com](mailto:support@levoit.com)

**Toll-Free:** 1-888-726-8520

## Support Hours

Mon–Fri, 9:00 am–5:00 pm PST/PDT

\*Please have your order invoice PDF or screenshot(s) ready before contacting Customer Support.

**lëvoit®**